

# RBW2 SERIES ROCKER SWITCH

ANTI-VANDAL SWITCHES  
 DETECTOR SWITCHES  
 DIP SWITCHES  
 KEYLOCK SWITCHES  
 NAVIGATION SWITCHES  
 PUSHBUTTON SWITCHES  
**ROCKER SWITCHES**  
 ROTARY SWITCHES  
 SLIDE SWITCHES  
 SNAP ACTION SWITCHES  
 TACTILE SWITCHES  
 TOGGLE SWITCHES  
 CAP OPTIONS

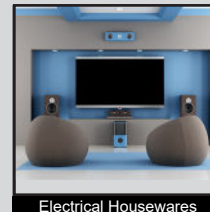

## APPLICATIONS / MARKETS

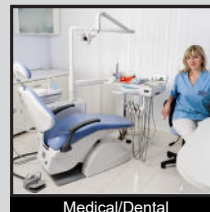
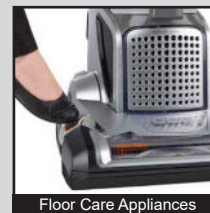
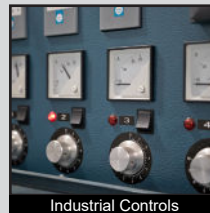

**RoHS**

## SPECIFICATIONS

**Electrical Rating:** 16(16)A 125VAC 5E4 T85 [cURus]  
 1/3HP 125VAC IP66 [cURus],  
 10(10)A 250VAC [VDE]

**Electrical Life:** 50,000 Cycles  
**Mechanical Life:** 50,000 Cycles  
**Contact Resistance:** <30mΩ Max.  
**Insulation Resistance:** 500MΩ Min. at 500VDC  
**Dielectric Strength:** 1,000VAC for 1 Minute  
**Operating Temperature:** -20°C to 85°C  
**Ingress Protection:** IP66  
**Panel Cutout:** 22mm x 30mm  
**Function:** DPST, Off-On DPDT, On-On

## FEATURES & BENEFITS

- Full illumination options available
- Approved under new UL 61058-1 rating
- UL approved up to 1/3HP
- VDE approved up to 10A
- Internally sealed to an IP66 rating using patented technology (Patent No.: US 7,872,205 B2)

## PART NUMBER CONFIGURATOR

Series	Circuit	Body Color	Actuator Color	Marking	Termination	Lamp Voltage
<input type="text" value="RBW2"/>	<input type="text" value="A"/>	<input type="text" value="BLK"/>	<input type="text" value="BLK"/>	<input type="text" value="E"/>	<input type="text" value="F"/>	<input type="text" value="0"/>
RBW2	A - Off-On (DPST) *B - On-On (DPDT)	BLK - Black	BLK - Black RED - Red RIL - Red Full Illumin. GIL - Green Full Illumin.	E - No Marking A - Dot D - I/II Vertical F - I/O Vertical G - I/O Horizontal I - On/Off Vertical	F - 6.3mm Tab	0 - No Lamp 1 - 125VAC Neon 2 - 250VAC Neon

\* Not available with Illumination

Specifications subject to change without notice 6.11.2024



**E-SWITCH®**

www.e-switch.com

800.867.2717

1

# RBW2 SERIES ROCKER SWITCH

## BODY DIMENSIONS A - CIRCUIT

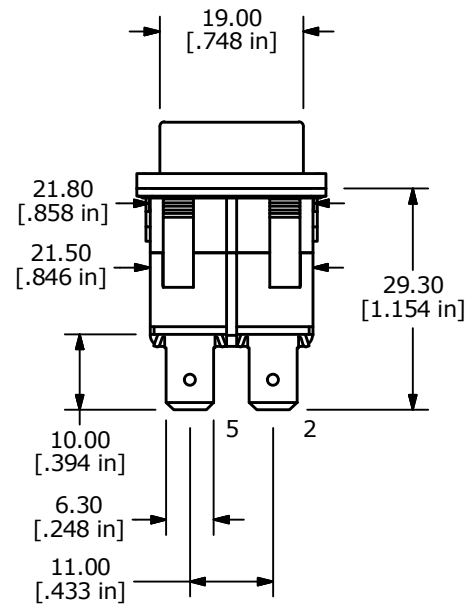
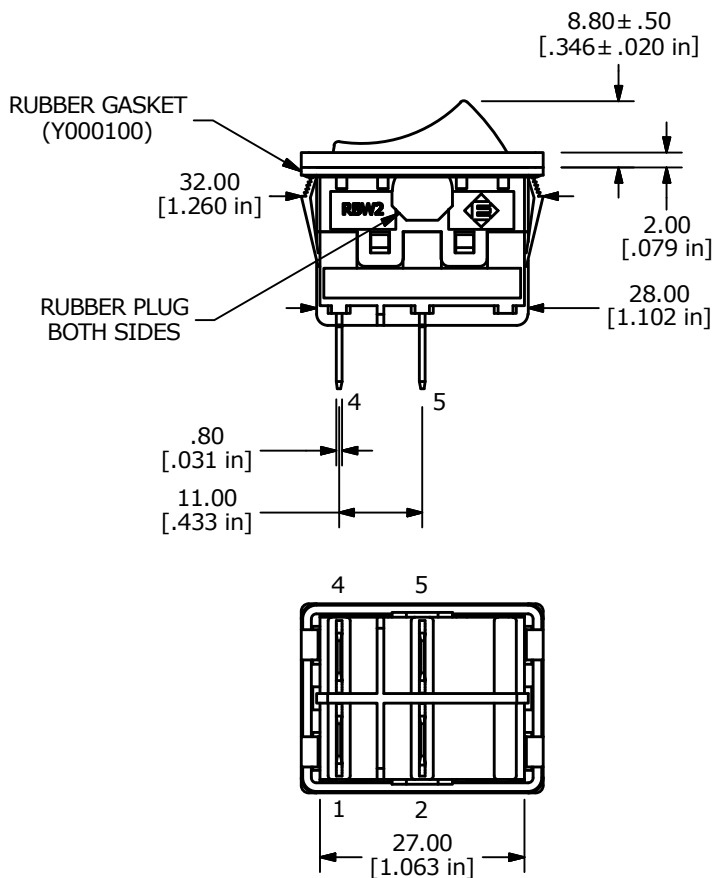
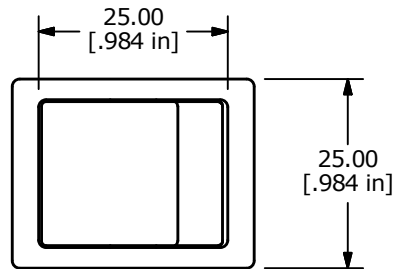
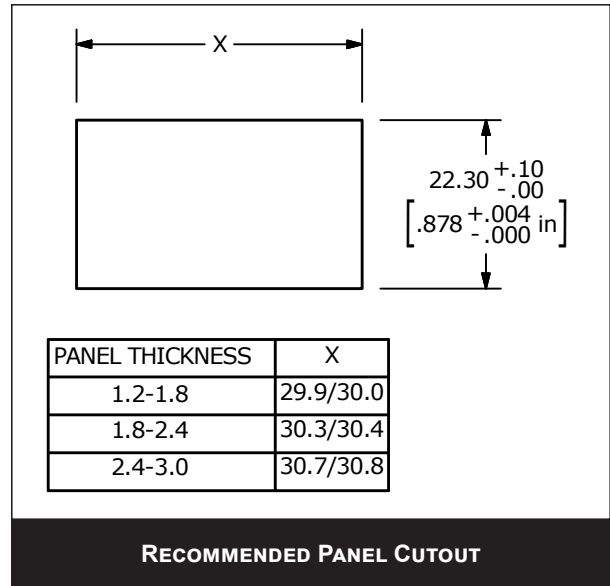
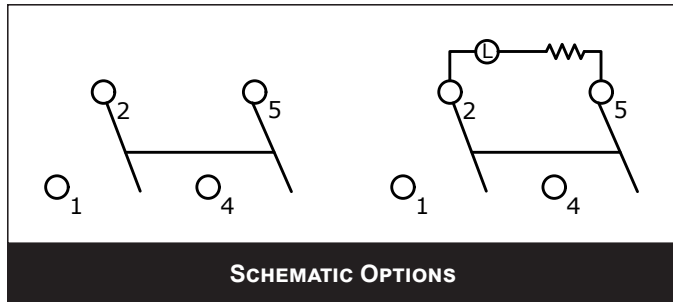

# RBW2 SERIES ROCKER SWITCH

## BODY DIMENSIONS B - CIRCUIT

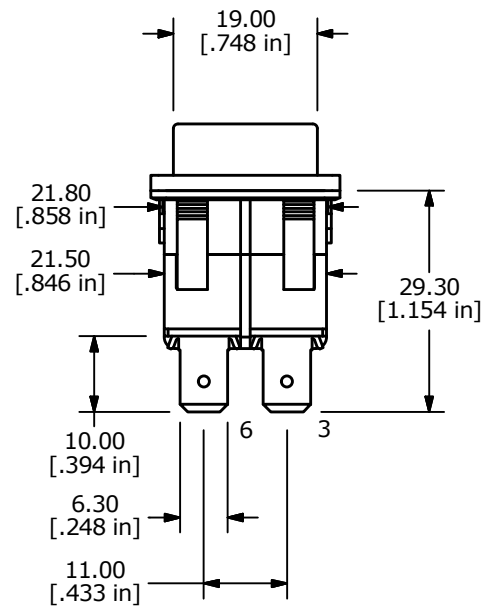
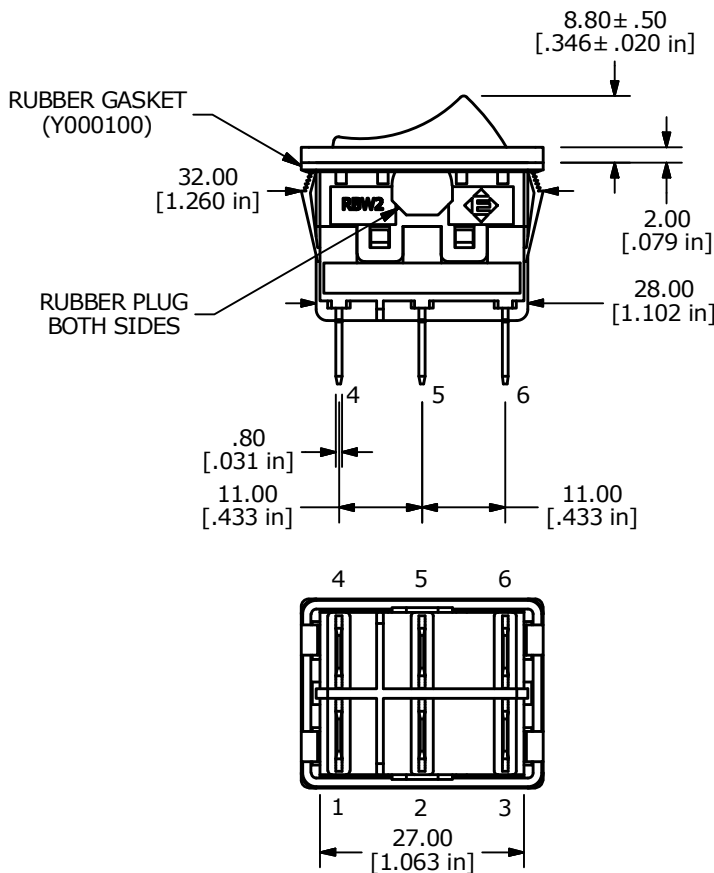
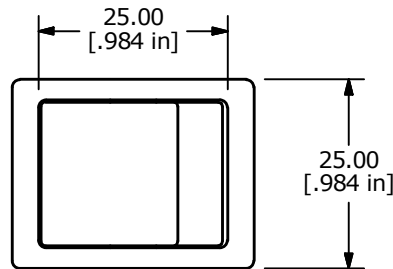
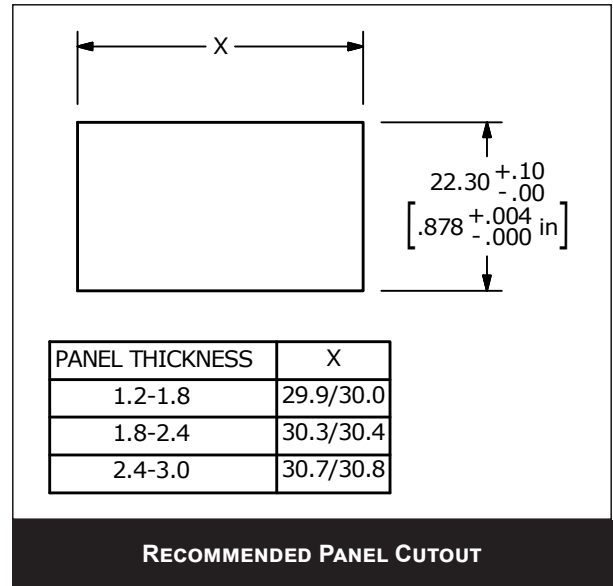
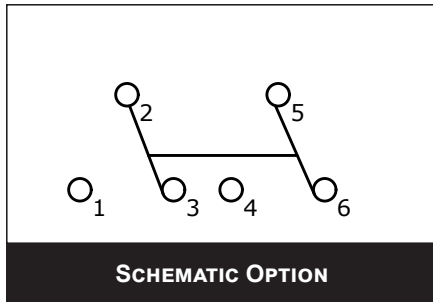

# RBW2 SERIES ROCKER SWITCH

## MARKING OPTIONS

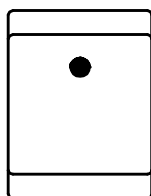

**A - DOT**

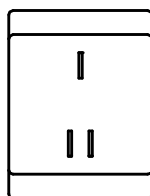

**D - I/II  
VERTICAL**

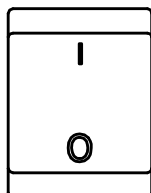

**F - I/O  
VERTICAL**

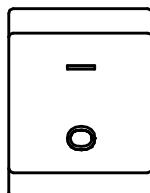

**G - I/O  
HORIZONTAL**

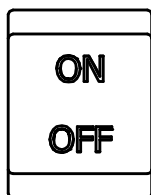

**I - ON/OFF  
VERTICAL**

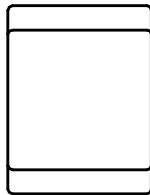

**E - No MARKING**

ANTI-VANDAL  
SWITCHES

DETECTOR  
SWITCHES

DIP  
SWITCHES

KEYLOCK  
SWITCHES

NAVIGATION  
SWITCHES

PUSHBUTTON  
SWITCHES

**ROCKER  
SWITCHES**

ROTARY  
SWITCHES

SLIDE  
SWITCHES

SNAP ACTION  
SWITCHES

TACTILE  
SWITCHES

TOGGLE  
SWITCHES

CAP  
OPTIONS

