

TL6150 SERIES TACT SWITCH

ANTI-VANDAL SWITCHES
 DETECTOR SWITCHES
 DIP SWITCHES
 KEYLOCK SWITCHES
 NAVIGATION SWITCHES
 PUSHBUTTON SWITCHES
 ROCKER SWITCHES
 ROTARY SWITCHES
 SLIDE SWITCHES
 SNAP ACTION SWITCHES
TACTILE SWITCHES
 TOGGLE SWITCHES
 CAP OPTIONS

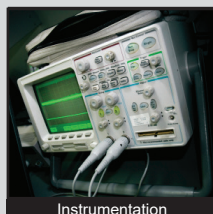

APPLICATIONS / MARKETS

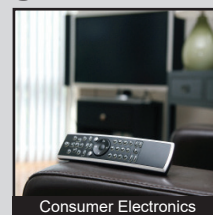
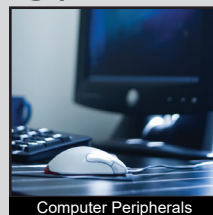
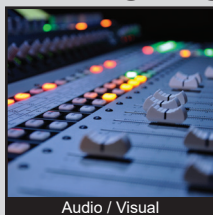

RoHS

SPECIFICATIONS

Contact Rating: 50mA, 32VDC
Electrical Life: up to 5,000,000 Cycles
Contact Resistance: 100mΩ Max. (Initial)
Insulation Resistance: 10MΩ Min. at 100VDC
Dielectric Strength: 250VAC for 1 Minute
Operating Temperature: -40°C to 85°C
Operating Force: 160gf ± 50gf (5,000,000 cycles)
 200gf ± 50gf (500,000 cycles)
 350gf ± 100gf (300,000 cycles)
Travel: 0.3mm; 160gf
 0.35mm; 200gf
 0.5mm; 350gf
Dust/Moisture Protection: IP67
Function: SPST, Off-(On)

FEATURES & BENEFITS

- Up to 5,000,000 cycle life expectancy
- Tape and Reel packaging
- IP67 ratings
- Multiple force options

PART NUMBER CONFIGURATOR

Series	Circuit	Actuator	Force	Plating	Termination
<input type="text" value="TL"/>	<input type="text" value="6150"/>	<input type="text" value="A - 3.50"/> <input type="text" value="B - 5.20"/>	<input type="text" value="F160 - 160 gf - Brown"/> <input type="text" value="F200 - 200 gf - Red"/> <input type="text" value="F350 - 350 gf - Orange"/>	<input type="text" value="Q - Silver"/>	<input type="text" value="G - Gull Wing"/> <input type="text" value="J - J Lead"/>

Specifications subject to change without notice 2.9.2021



E-SWITCH®

www.e-switch.com

800.867.2717

1

TL6150 SERIES TACT SWITCH

BODY DIMENSIONS GULL WING

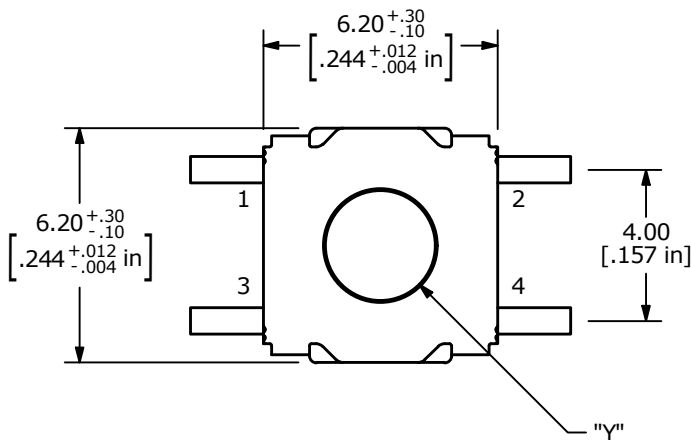
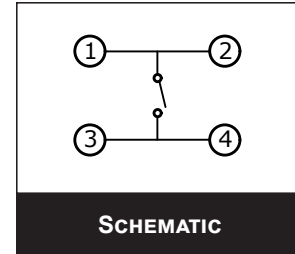
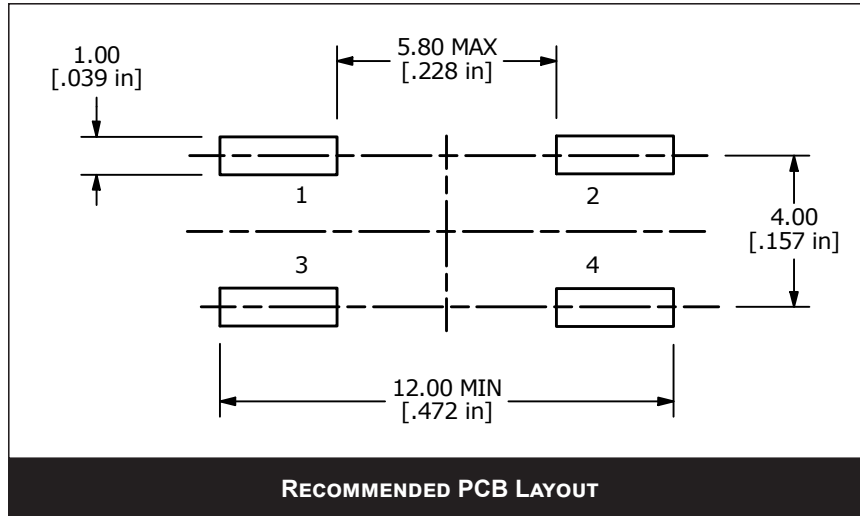

ACTUATOR	"X"	"Y"
A	3.50	2.90
B	5.20	2.70

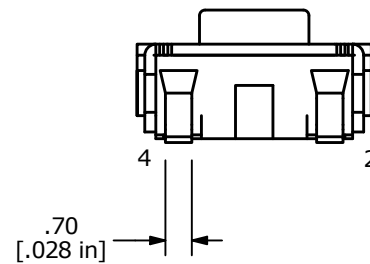
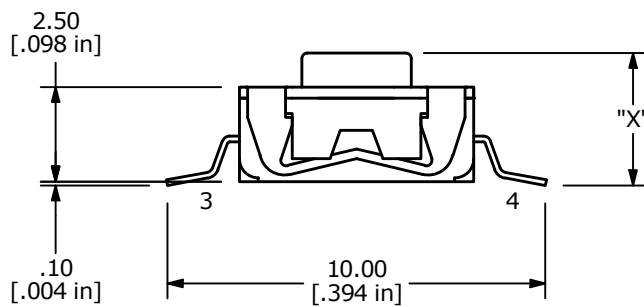

TL6150 SERIES TACT SWITCH

BODY DIMENSIONS J LEAD

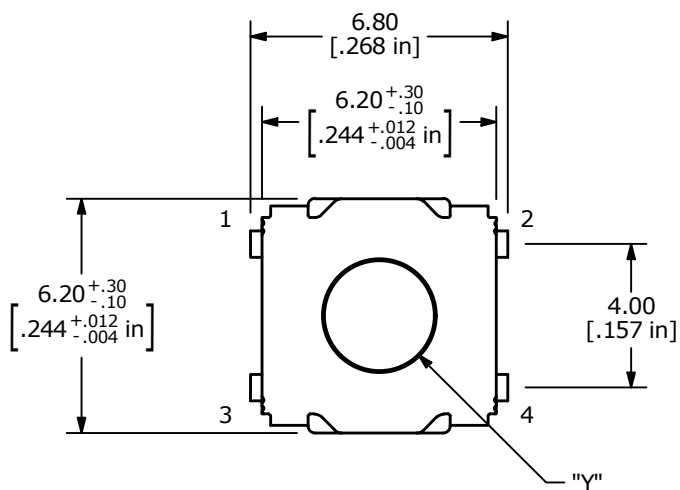
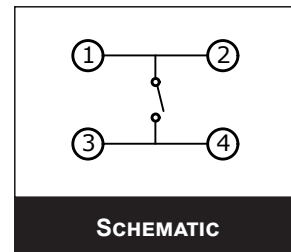
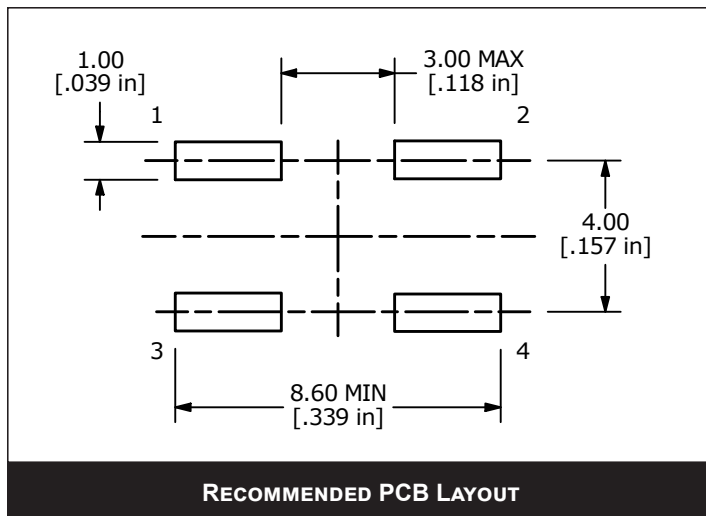

ACTUATOR	"X"	"Y"
A	3.50	2.90
B	5.20	2.70

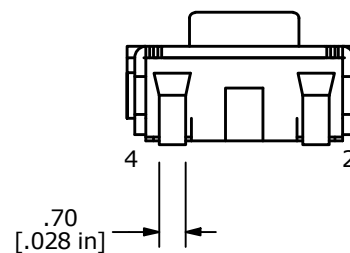
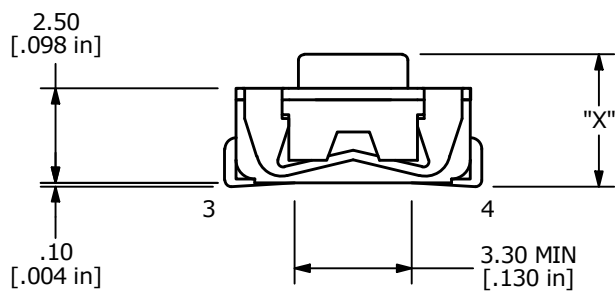

TL6150 SERIES TACT SWITCH

BODY DIMENSIONS TAPE AND REEL

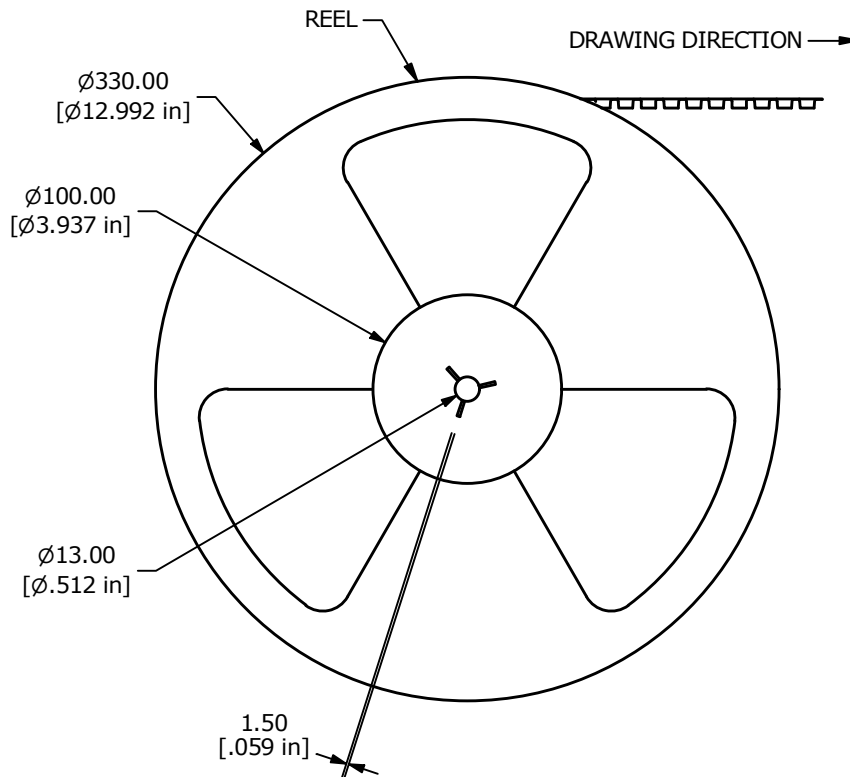
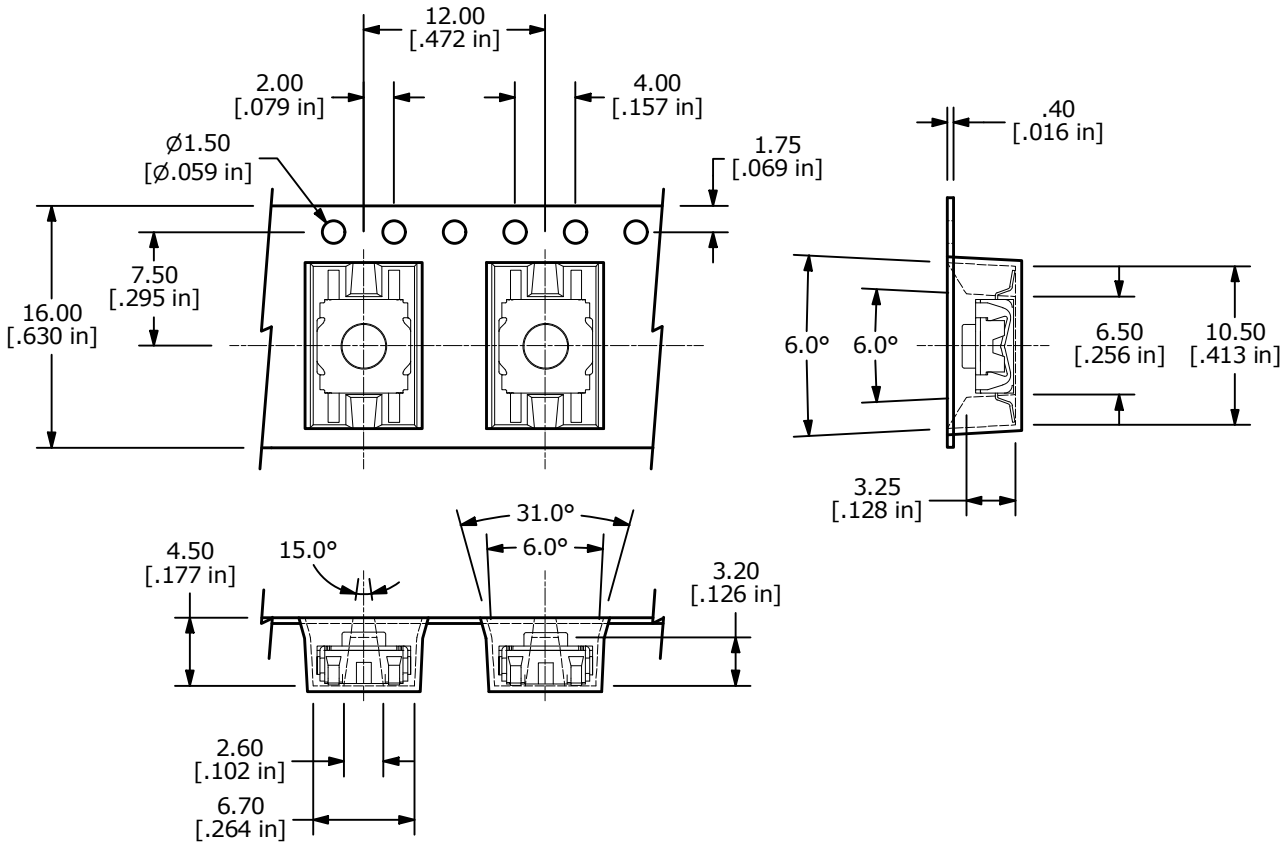

TL6150 SERIES TACT SWITCH

RECOMMENDED SOLDER PROCESS

Most contamination problems can be prevented by exercising care during the cleaning and soldering process. Care should be taken not to immerse or spray unsealed switches during flux removal. Contact E-Switch for specific soldering recommendations and specifications not shown. Generalized soldering procedures are outlined below.

“TYPICAL” SMT REFLOW (Pb and Pb-Free)

Profile Feature	Sn-Pb Eutectic Assembly	Pb-Free Assembly
Average Ramp-Up Rate ($T_{s_{max}}$ to T_p)	3 °C/second max.	3 °C/second max.
Preheat		
-Temperature Min ($T_{s_{min}}$)	100 °C	150 °C
-Temperature Max ($T_{s_{max}}$)	150 °C	200 °C
-Time ($t_{s_{min}}$ to $t_{s_{max}}$)	60-120 seconds	60-180 seconds
Time Maintained above:		
-Temperature (T_L)	183 °C	217 °C
-Time (t_L)	60-150 seconds	60-150 seconds
Time within 5 °C of actual Peak Temperature (t_p)	10-30 seconds	20-40 seconds
Ramp-Down Rate	6 °C/second max.	6 °C/second max.
Time 25 °C to Peak Temperature	6 minutes max.	8 minutes max.

Note 1: All temperatures refer to topside of the package, measured on the package surface.

